

Systemnahe Programmierung in C (SPiC)

16 μ C-Systemarchitektur – Prozessor

Jürgen Kleinöder, Daniel Lohmann, Volkmar Sieh

Lehrstuhl für Informatik 4
Verteilte Systeme und Betriebssysteme

Friedrich-Alexander-Universität
Erlangen-Nürnberg

Sommersemester 2020

http://www4.cs.fau.de/Lehre/SS20/V_SPiC



Beispiel ATmega32: Blockschaltbild

CPU-Kern
Speicher

Peripherie

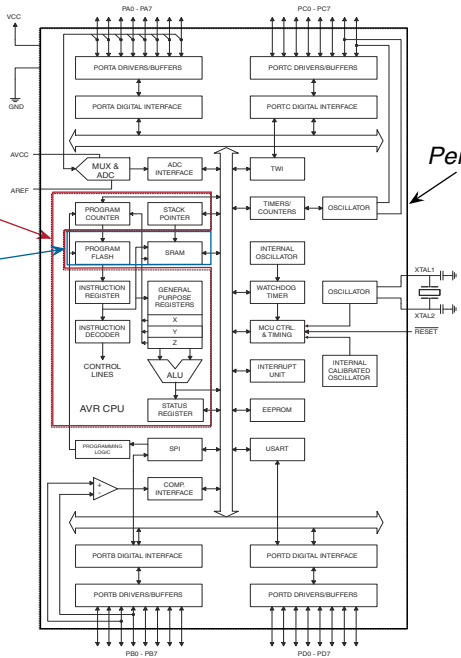

Beispiel ATmega-Familie: CPU-Architektur

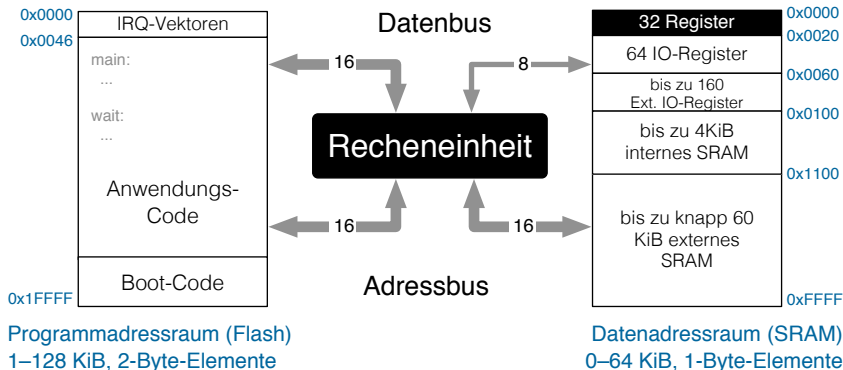

- Harvard-Architektur (getrennter Speicher für Code und Daten)
- Peripherie-Register sind in den Speicher eingebündelt
~> ansprechbar wie globale Variablen



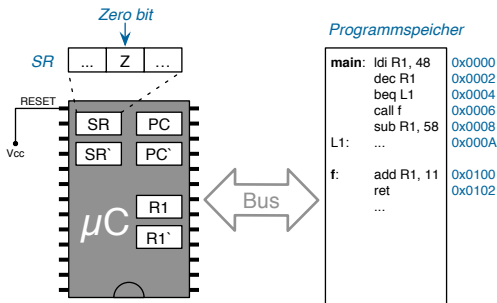

- Hier am Beispiel eines sehr einfachen Pseudoprocessors
 - Nur ein Vielzweckregister (R1)
 - Programmzähler (PC) und Statusregister (SR) (+ „Schattenkopien“)
 - Kein Datenspeicher, kein Stapel ~> Programm arbeitet nur auf Registern



Wie arbeitet ein Prozessor?

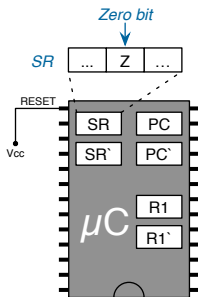

Programmspeicher

```
main: ldi R1, 48 0x0000
      dec R1    0x0002
      beq L1   0x0004
      call f   0x0006
      sub R1, 58 0x0008
      0x000A
L1:   ...
f:   add R1, 11 0x0100
      ret      0x0102
      ...
```

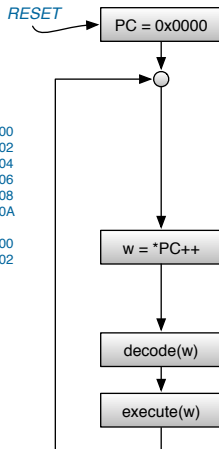

Wie arbeitet ein Prozessor?

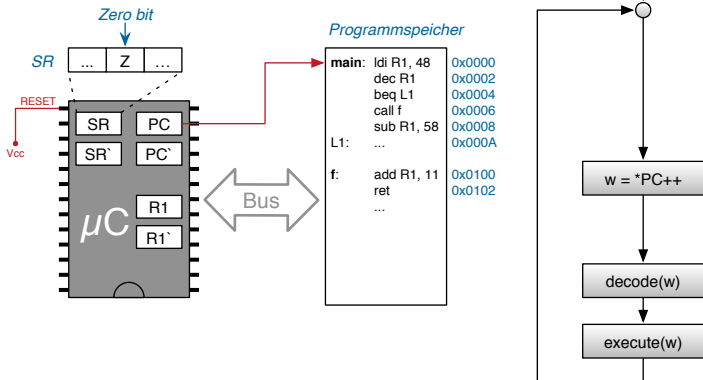

Wie arbeitet ein Prozessor?

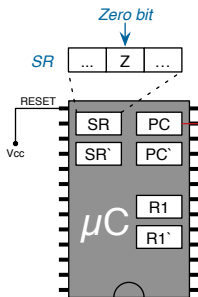

Programmspeicher

main:	<code>ldi R1, 48</code>	0x0000
	<code>dec R1</code>	0x0002
	<code>beq L1</code>	0x0004
	<code>call f</code>	0x0006
	<code>sub R1, 58</code>	0x0008
	<code>ret</code>	0x000A
L1:	<code>...</code>	
f:	<code>add R1, 11</code>	0x0100
	<code>ret</code>	0x0102
	<code>...</code>	

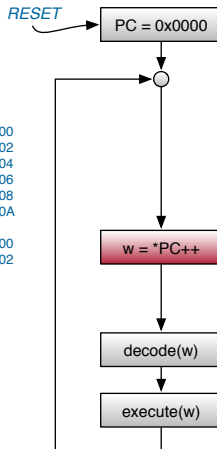

Wie arbeitet ein Prozessor?

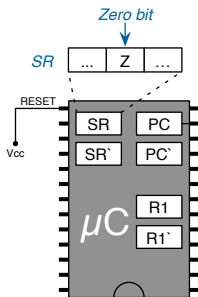

Programmspeicher

main:	<code>ldi R1, 48</code>	0x0000
	<code>dec R1</code>	0x0002
	<code>beq L1</code>	0x0004
	<code>call f</code>	0x0006
	<code>sub R1, 58</code>	0x0008
	<code>ret</code>	0x000A
L1:	<code>...</code>	
f:	<code>add R1, 11</code>	0x0100
	<code>ret</code>	0x0102
	<code>...</code>	

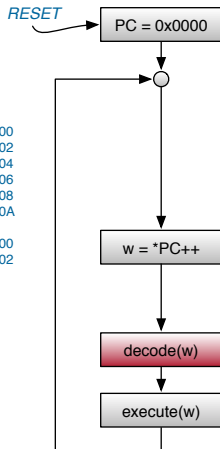

Wie arbeitet ein Prozessor?

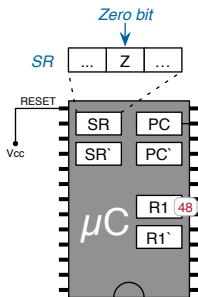

Programmspeicher

main:	<code>ldi R1, 48</code>	0x0000
	<code>dec R1</code>	0x0002
	<code>beq L1</code>	0x0004
	<code>call f</code>	0x0006
	<code>sub R1, 58</code>	0x0008
	<code>ret</code>	0x000A
L1:	<code>...</code>	
f:	<code>add R1, 11</code>	0x0100
	<code>ret</code>	0x0102
	<code>...</code>	

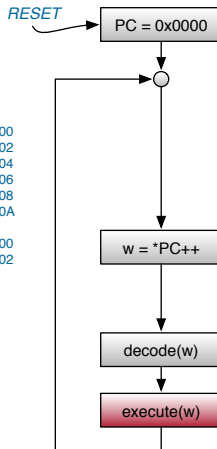

Wie arbeitet ein Prozessor?

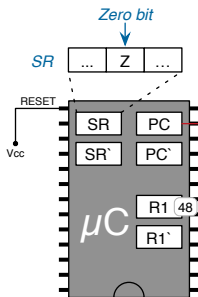

Programmspeicher

main:	ldi R1, 48	0x0000
	dec R1	0x0002
	beq L1	0x0004
	call f	0x0006
	sub R1, 58	0x0008
	...	0x000A
L1:	...	
f:	add R1, 11	0x0100
	ret	0x0102
	...	

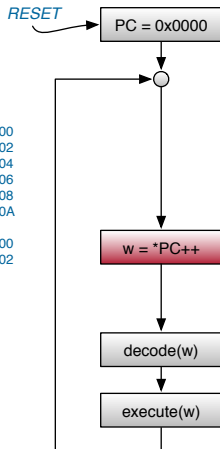

Wie arbeitet ein Prozessor?

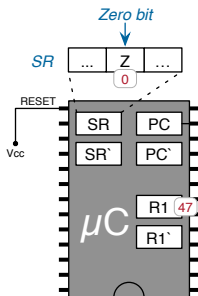

Programmspeicher

```
main: ldi R1, 48 0x0000
      dec R1    0x0002
      beq L1   0x0004
      call f   0x0006
      sub R1, 58 0x0008
      ...     0x000A
L1:   ...
f:   add R1, 11 0x0100
      ret      0x0102
      ...
```



```
w: dec <R>
R -= 1
if(R == 0) Z = 1
else Z = 0
```

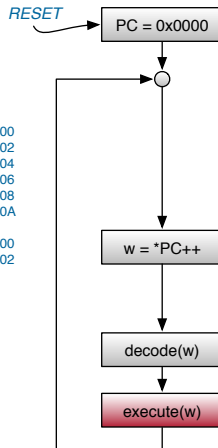

Wie arbeitet ein Prozessor?

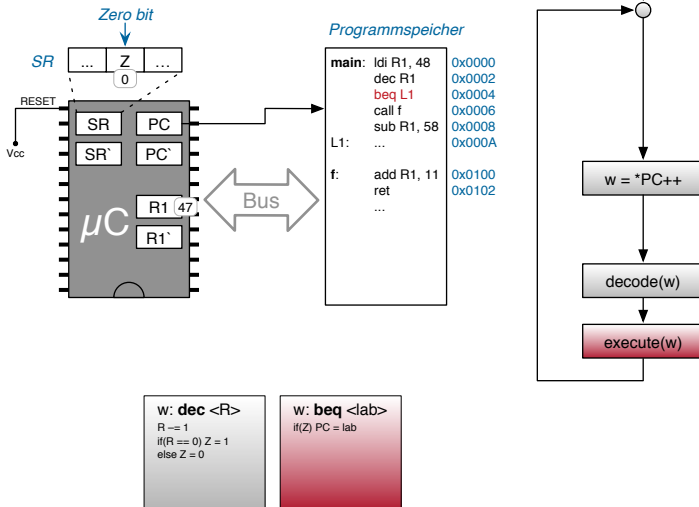

Wie arbeitet ein Prozessor?

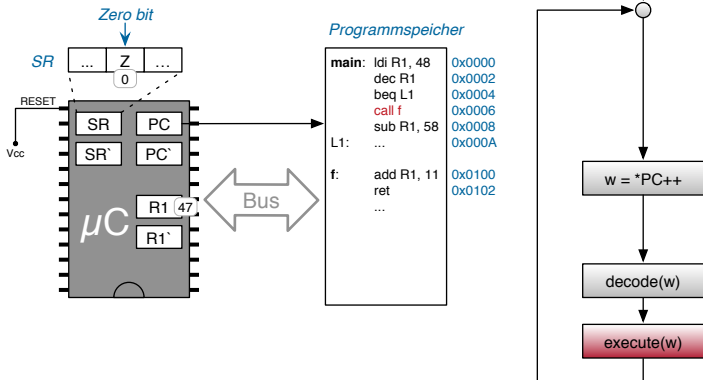

w: dec <R>
R -= 1
if(R == 0) Z = 1
else Z = 0

w: beq <lab>
if(Z) PC = lab

w: call <func>
PC' = PC
PC = func



Wie arbeitet ein Prozessor?

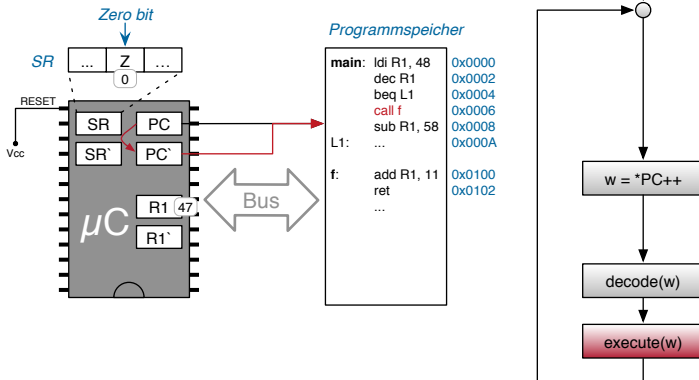

w: dec <R>
R -= 1
if(R == 0) Z = 1
else Z = 0

w: beq <lab>
if(Z) PC = lab

w: call <func>
PC' = PC
PC = func



Wie arbeitet ein Prozessor?

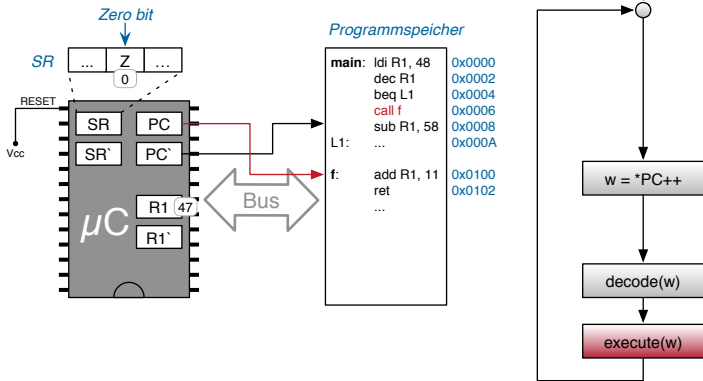

w: dec <R>
R -= 1
if(R == 0) Z = 1
else Z = 0

w: beq <lab>
if(Z) PC = lab

w: call <func>
PC' = PC
PC = func



Wie arbeitet ein Prozessor?

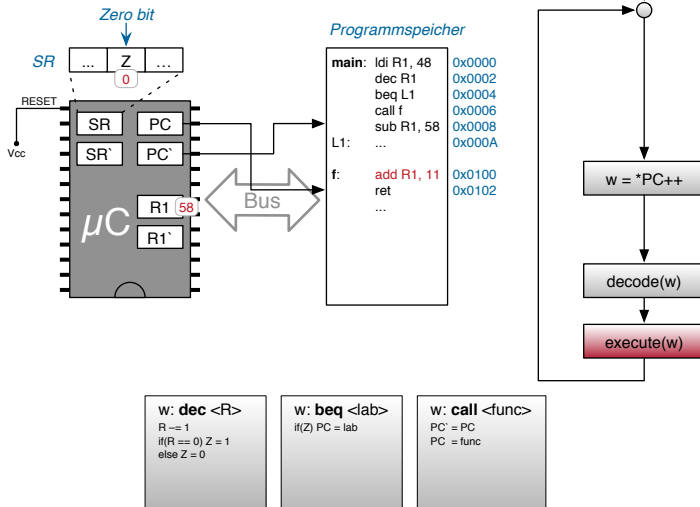

Wie arbeitet ein Prozessor?

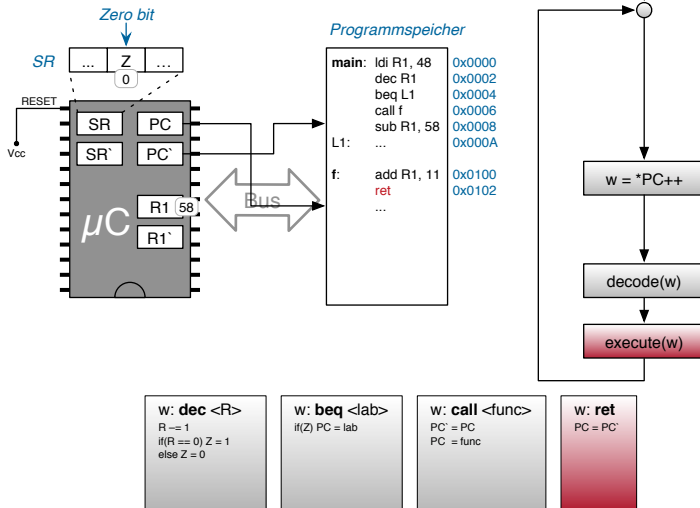

Wie arbeitet ein Prozessor?

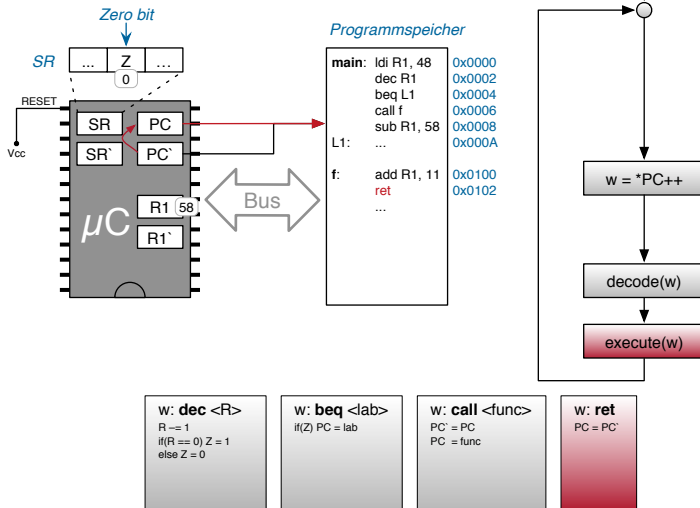

Wie arbeitet ein Prozessor?

